



# 18 GA. STAINLESS STEEL WORK TABLES

STAINLESS STEEL

## TTS Series



Fully Adjustable Leg Collar



Item #: \_\_\_\_\_ Qty #: \_\_\_\_\_  
 Model #: \_\_\_\_\_  
 Project #: \_\_\_\_\_

### FEATURES:

Top is furnished with 1 5/8" sanitary rolled rim on front and rear; and square ends.

Two die formed hat channels are attached to underside of work table top to reinforce and maintain a level working surface.

Leg Collar at undershelf corner secures leg shelf to legs and is fully adjustable.

### CONSTRUCTION:

All TIG welded. Exposed weld areas polished to match adjacent surface.

Top is sound deadened.

Die formed galvanized hat channels are secured to top by means of structural adhesive and weld studs.

Gussets welded to hat channels.

### MATERIAL:

**TOP:** 18 Gauge Stainless Steel Type "430" Series

**SHELF:** 18 Gauge Stainless Steel with Stainless Steel Gussets

**LEGS:** 1 5/8" Diameter Tubular Stainless Steel Steel 1" Stainless Steel Legs & Bullet Feet

L	18" WIDE			24" WIDE			30" WIDE		
	Model	Approx. Wt.	Approx. Cu. Ft.	Model	Approx. Wt.	Approx. Cu. Ft.	Model	Approx. Wt.	Approx. Cu. Ft.
24"	TTS-182-X	27 lbs.	2	TTS-242-X	36 lbs.	2	TTS-302-X	52 lbs.	3
30"	TTS-180-X	30 lbs.	2	TTS-240-X	40 lbs.	2	TTS-300-X	50 lbs.	3
36"	TTS-183-X	33 lbs.	3	TTS-243-X	44 lbs.	2	TTS-303-X	55 lbs.	3
48"	TTS-184-X	38 lbs.	3	TTS-244-X	52 lbs.	3	TTS-304-X	64 lbs.	4
60"	TTS-185-X	42 lbs.	4	TTS-245-X	60 lbs.	4	TTS-305-X	73 lbs.	5
72"	TTS-186-X	48 lbs.	5	TTS-246-X	68 lbs.	4	TTS-306-X	82 lbs.	5
84"	--	--	--	TTS-247-X*	75 lbs.	5	--	--	--
96"	TTS-188-X*	60 lbs.	7	TTS-248-X*	88 lbs.	9	TTS-308-X*	105 lbs.	11

\*7' and 8' tables furnished with 6 legs

## DETAILS and SPECIFICATIONS

TOL ± .500"

ALL DIMENSIONS ARE TYPICAL

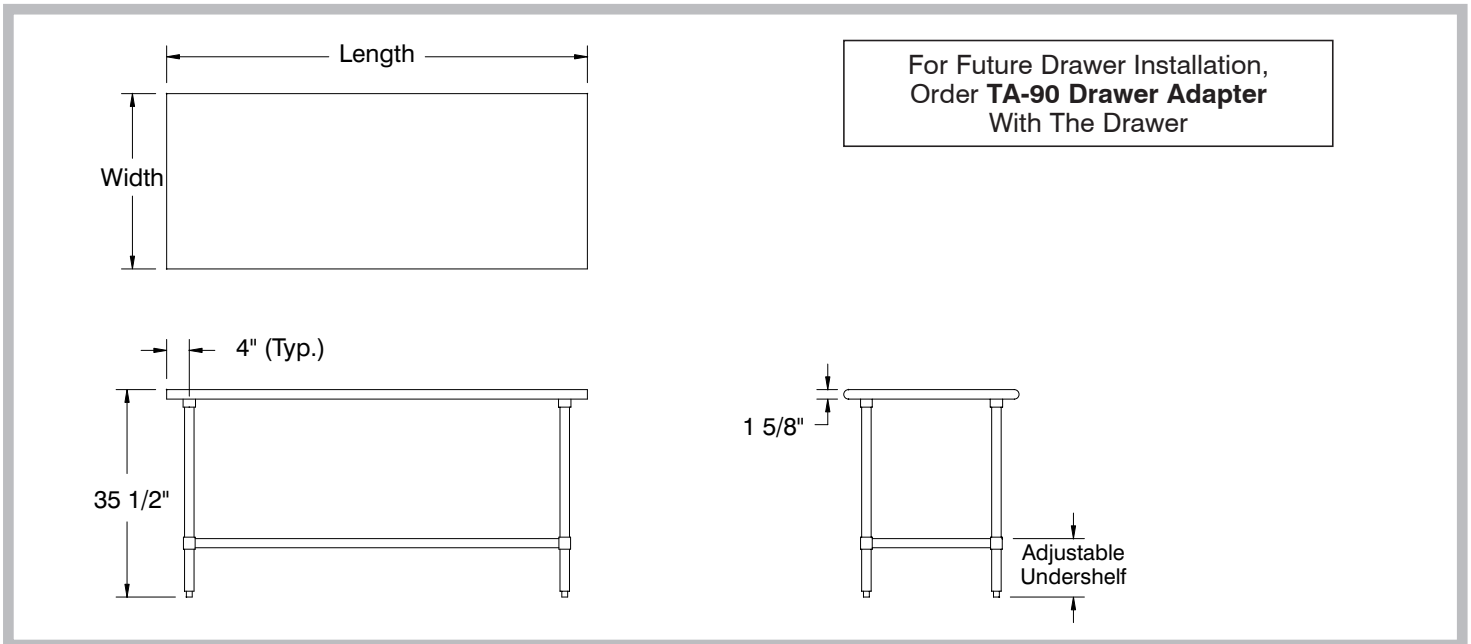

Customer Service Available To Assist You 1-800-645-3166 8:30 am - 7:00 pm E.S.T.

For Orders & Customer Service:

Email: customer@advancetabco.com or Fax: 631-242-6900

For Smart Fabrication™ Quotes:

Email: smartfab@advancetabco.com or Fax: 631-586-2933