



STAINLESS STEEL  
**DISHTABLES**  
**CORNER SOIL**

**NEW** Tile Edge Design



DTS-K30-60R Shown

**10-1/2" EXTRA LARGE**  
**Bold Looking Backsplash**  
**with 2" return and tile edge**

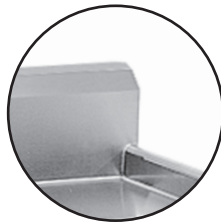

Item #: \_\_\_\_\_ Qty #: \_\_\_\_\_  
 Model #: \_\_\_\_\_  
 Project #: \_\_\_\_\_

**Spec-Line:** 14 ga. 304 Series Stainless Steel Top.  
 16 ga. 304 Stainless Steel Legs Stainless Steel Legs  
 with Welded Cross Bracing & Stainless Steel Bullet Feet.

**UPGRADED!**  
**Standard:** 16 ga. 304 Series Stainless Steel Top.  
 16 ga. 304 Stainless Steel Legs Stainless Steel Legs  
 with Welded Cross Bracing & Stainless Steel Bullet Feet.

**FEATURES:**

Tile edge for ease of installation.  
 STANDARD SOIL section features 5" deep sink bowl.  
 SPEC-LINE SOIL section features 8" deep sink bowl.  
 Dishtable system consists of SOIL and CLEAN sections.  
 Table is furnished with 10-1/2" splash with a 2" return.

**CONSTRUCTION:**

All TIG welded.  
 Welded areas blended to match adjacent surfaces and to a satin finish.  
 Stainless Steel Gussets welded to a stainless steel support channel.

**MECHANICAL:**

Faucet holes in SPLASH punched on 8" centers, faucet not included.  
 Waste drain is 1 1/2" IPS basket type and is included.

ACCESSORIES	Model #	Qty
Faucet		
Wall Shelf		
Undershelf		

<b>14 Gauge 304</b> 16 Ga. Stainless Steel Legs	<b>16 Gauge 304</b> Stainless Steel Legs
--	---

Nominal Size	"L"	SPEC-LINE	STANDARD	Approx. Wt.
4 Ft.	47"	DTS-K30-48L or R	DTS-K70-48L or R	165 lbs.
5 Ft.	59"	DTS-K30-60L or R	DTS-K70-60L or R	190 lbs.
6 Ft.	71"	DTS-K30-72L or R	DTS-K70-72L or R	215 lbs.
7 Ft.	83"	DTS-K30-84L or R	DTS-K70-84L or R	225 lbs.
8 Ft.	95"	DTS-K30-96L or R	DTS-K70-96L or R	240 lbs.
9 Ft.	107"	DTS-K30-108L or R	DTS-K70-108L or R	355 lbs.
10 Ft.	119"	DTS-K30-120L or R	DTS-K70-120L or R	380 lbs.
12 Ft.	143"	DTS-K30-144L or R	DTS-K70-144L or R	390 lbs.

Nominal sizing on all dishtables for ease of installation.



**Customer Service Available To Assist You 1-800-645-3166 8:30 am - 7:00 pm E.S.T.**

For Orders & Customer Service:  
 Email: customer@advancetabco.com or Fax: 631-242-6900

For Smart Fabrication™ Quotes:  
 Email: smartfab@advancetabco.com or Fax: 631-586-2933

# DIMENSIONS and SPECIFICATIONS

TOL ± .500"

ALL DIMENSIONS ARE TYPICAL

**SEE DISH MACHINE COMPATIBILITY CHART TO ENSURE PROPER FIT**  
 Dish Machine Compatibility Chart can be found on our website at [www.advancetabco.com](http://www.advancetabco.com) under "Product Support"

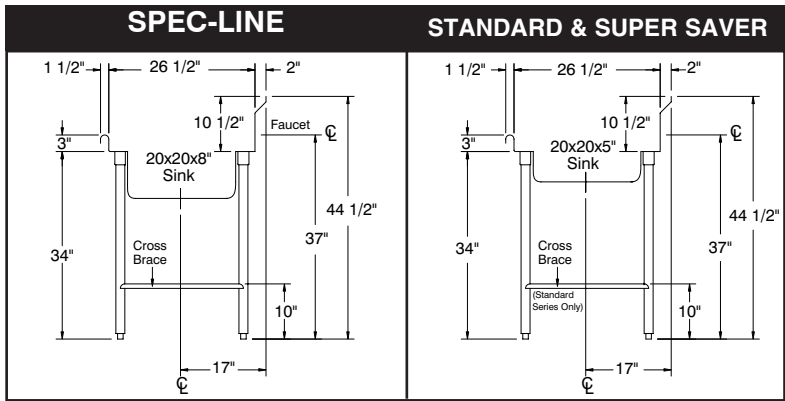
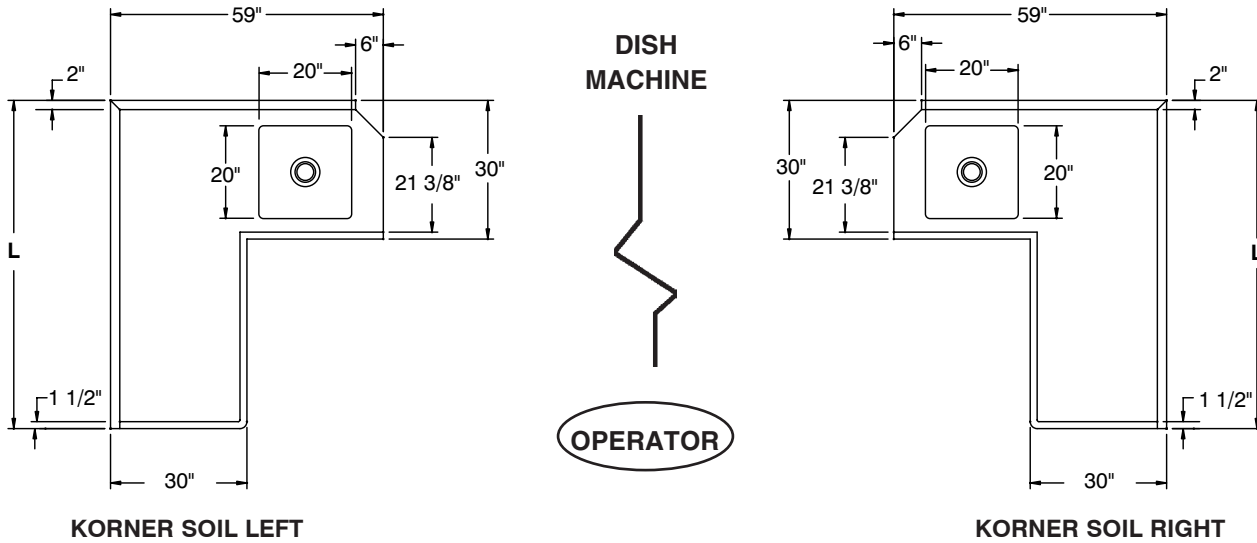

*CUSTOMIZE YOUR OWN SYSTEM  
 by Ordering Optional Accessories from our  
 PRODUCT & PRICE GUIDE*

Splash Detail

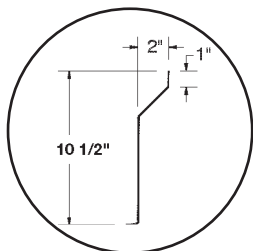

Description	SPEC-LINE	STANDARD
<b>Material</b>	<b>14 Ga. 304 Series</b>	<b>16 Ga. 304 Series</b>
<b>1 5/8" Dia. Legs</b>	Stainless Steel	Stainless Steel
<b>Gussets</b>	Stainless Steel	Stainless Steel
<b>Bullet Feet (1" adj.)</b>	Stainless Steel	Stainless Steel
<b>Cross Bracing</b>	Welded	Welded
<b>Prerinse Bowl Depth</b>	8"	5"
<b>Prerinse Basket</b>	Included	Optional

