



SG-1 MOUNTING BRACKET FOR FIELD INSTALLATION OF FOOD SHIELDS & OVERSHELVES

FITS 1" POSTS



Item #: _____ Qty #: _____

Model #: _____

Project #: _____

FEATURES:

For use when access below the countertop is not available

One required for each leg

Three mounting holes (Hardware not included)

For use with 1" round posts

2" diameter base

Set screw secures post to bracket.
(Requires 5/64" Allen Key).

Compatible with all Advance Tabco Food Shields

MATERIAL:

Brushed Stainless Steel

Installation hardware by others, not required if shelf is ordered at same time as table, table will be prepared for mounting

DETAILS and SPECIFICATIONS

TOL $\pm .500"$

ALL DIMENSIONS ARE TYPICAL

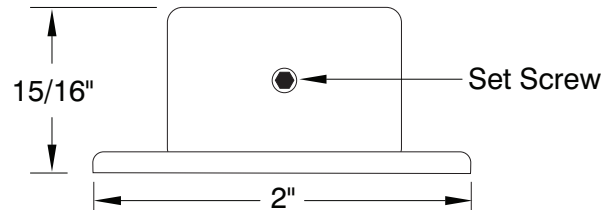
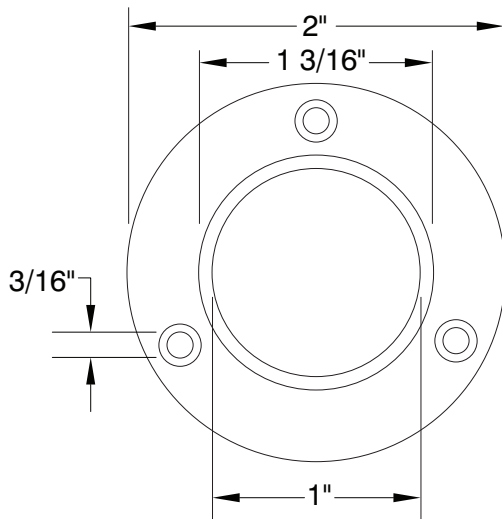

Customer Service Available To Assist You 1-800-645-3166 8:30 am - 7:00 pm E.S.T.

For Orders & Customer Service:

Email: customer@advancetabco.com or Fax: 631-242-6900

For Smart Fabrication™ Quotes:

Email: smartfab@advancetabco.com or Fax: 631-586-2933