



HEAVY DUTY ICE-COOLED TABLES WITH ENCLOSED BASE



Enclosed Base
 HD CPU-3-BS Shown
 with Optional TA-255P Casters

Item #: _____ Qty #: _____
 Model #: _____
 Project #: _____

FEATURES:

- Heavy duty construction
- All welded 300 series stainless steel
- Fiberglass insulation
- Uses standard 12" x 20" pans, and smaller pans with the use of optional adapter bars (NOT INCLUDED)
- Stainless steel shelf with removable 3/8" thick poly cutting board - Ships K.D.

MATERIAL:

- CABINET BASE:** 18 gauge #304 stainless steel
- LINER:** 8" deep, 18 gauge #302 stainless steel welded
- CUTTING BOARD:** White Thermoplastic
- INSULATION:** Fiberglass
- LEGS:** 16 gauge stainless steel with full adjustable stainless steel bullet foot

Model	Length (L)	Width*	O.A. Inside Well Dim (A x B)	Wt (lbs.)	Cu. Ft.
HD CPU-2-BS	31 13/16"	36 1/4"	24 1/8" x 19 1/4"	117 lbs.	27
HD CPU-3-BS	47 1/8"	36 1/4"	39 1/2" x 19 1/4"	145 lbs.	39
HD CPU-4-BS	62 1/2"	36 1/4"	54 3/4" x 19 1/4"	205 lbs.	58
HD CPU-5-BS	77 3/4"	36 1/4"	70" x 19 1/4"	250 lbs.	69
HD CPU-6-BS	93 1/8"	36 1/4"	85 3/8" x 19 1/4"	295 lbs.	81

*Width Includes 8" Cutting Board

DIMENSIONS and SPECIFICATIONS

TOL ± .125"

ALL DIMENSIONS ARE TYPICAL

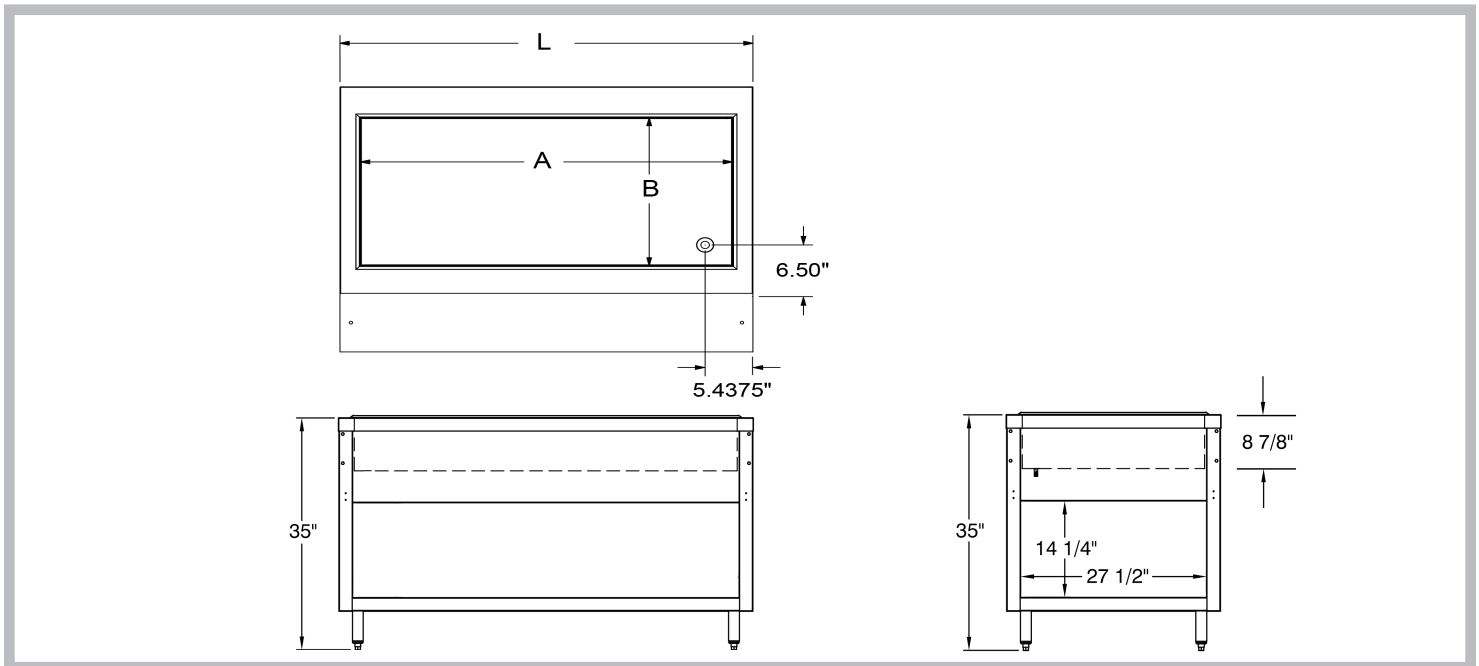

Customer Service Available To Assist You **1-800-645-3166** 8:30 am - 7:00 pm E.S.T.

For Orders & Customer Service:

Email: customer@advancetabco.com or Fax: 631-242-6900

For Smart Fabrication™ Quotes:

Email: smartfab@advancetabco.com or Fax: 631-586-2933

OPTIONAL ACCESSORIES

Food Table Shelving & Accessories

Visit our website for additional accessories



Acrylic Food Shield has 10" Clearance from Deck

**Double Sided
Self-Serve Buffet Shelf
with Built-In Food Shield**

Model	Length	Approx Wt.	Cu. Ft.
TBS-2	31-13/16"	34 lbs.	2
TBS-3	47-1/8"	42 lbs.	3
TBS-4	62-7/16"	47 lbs.	4
TBS-5	77-3/4"	55 lbs.	4
TBS-6	93-1/8"	63 lbs.	4

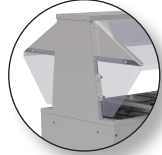

**Acrylic Side Panels
for Buffet Shelf**
Add side panels to meet
additional NSF requirements
(2 panels per end)
TBP-1 One End
TBP-2 Two Ends
Field Installation Available



Acrylic Food Shield has 1" Clearance from Deck

**Single Sided
Cafeteria Shelf
with Built-In Food Shield**

Model	Length	Approx Wt.	Cu. Ft.
TSS-2	31-13/16"	18 lbs.	2
TSS-3	47-1/8"	23 lbs.	3
TSS-4	62-7/16"	30 lbs.	4
TSS-5	77-3/4"	35 lbs.	4
TSS-6	93-1/8"	41 lbs.	4

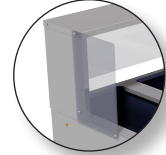

**Acrylic Side Panel
for Serving Shelf**
Add side panels to meet
additional NSF requirements.
(1 panel per end)
TSP-1 One end
TSP-2 Two Ends
Field Installation Available

Optional Adapter Rails & Bars

HDCPU SERIES		
Model #	Fits Model:	Description
SU-P-502	HDCPU-2-BS	Two Left To Right Rails & Three Front-To-Back Supports. Includes Mounting Screws.
SU-P-503	HDCPU-3-BS	Two Left To Right Rails & Four Front-To-Back Supports. Includes Mounting Screws.
SU-P-504	HDCPU-4-BS	Two Left To Right Rails & Five Front-To-Back Supports. Includes Mounting Screws.
SU-P-505	HDCPU-5-BS	Two Left To Right Rails & Six Front-To-Back Supports. Includes Mounting Screws.
SU-P-506	HDCPU-6-BS	Two Left To Right Rails & Seven Front-To-Back Supports. Includes Mounting Screws.

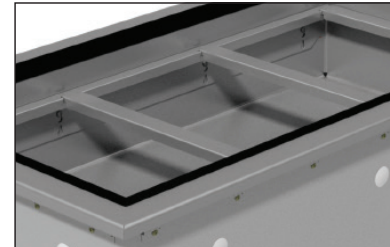

Left To Right Rails & Front To Back Supports Shown Above



Horizontal Adapter Bars
For Small Pan Sizes

12" x 1"

Model # SU-45A

Works With Required Rail Kits
(See Grid On Left)

