



# PORTABLE CASH REGISTER STAND WITH LOCKING DOOR



Includes Lock & Key

Item #: \_\_\_\_\_ Qty #: \_\_\_\_\_  
 Model #: \_\_\_\_\_  
 Project #: \_\_\_\_\_

### FEATURES:

- Flat top
- Locking door
- Mid-shelf
- Continuous perimeter bumpers
- Adjustable european flush mount hinges

### MATERIAL:

**CONSTRUCTION:** stainless steel construction (Interior, frame and bottom). Door, top and side panels are black laminate

**CASTERS:** Rubber

## DIMENSIONS and SPECIFICATIONS

TOL ± .125"

ALL DIMENSIONS ARE TYPICAL

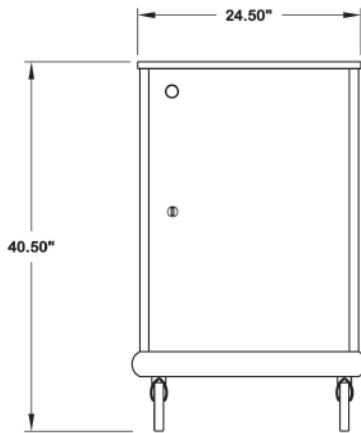
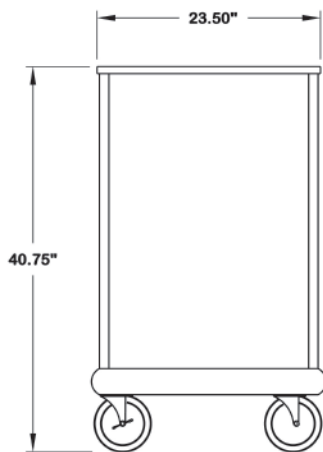

Model #	Weight	Cubic Ft.
AMD-2B	160	27

**Custom Colors Available!**

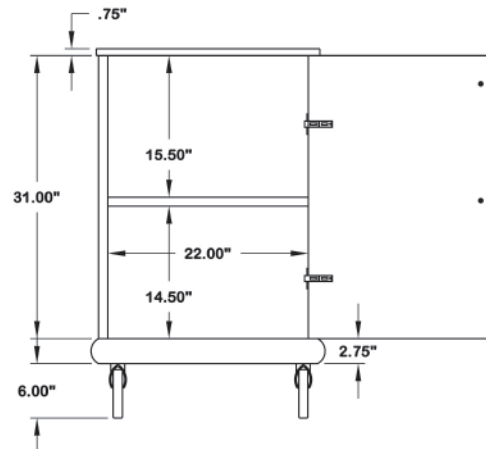

Customer Service Available To Assist You 1-800-645-3166 8:30 am - 7:00 pm E.S.T.

For Orders & Customer Service:  
 Email: customer@advancetabco.com or Fax: 631-242-6900

For Smart Fabrication™ Quotes:  
 Email: smartfab@advancetabco.com or Fax: 631-586-2933