



Edgewood, New York 11717-8380

10/2009



## Installation Instructions for TT Series Tables



**CHECK FOR CONCEALED DAMAGE  
FILE CLAIM WITH DELIVERING FREIGHT CARRIER**

Tables manufactured by **ADVANCE TABCO** are designed and constructed for applications including Food Preparation, Cooking, Manufacturing, Material Handling, Laboratory Service and the like. **ADVANCE TABCO** does not recommend product use for activities employing harsh and active chemicals. Consult factory regarding unusual applications.

# TABLES with Undershef

This package contains Table Top, Undershef, Legs & Set Screws

## Step 1:

Lay the table top flat on the box to protect the finish during assembly. (Figure 1)

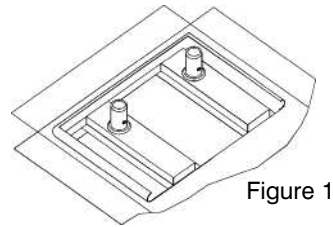

Figure 1

**NSF Installations require all set screws filled with an approved silicone sealer.**

## Step 2:

Insert set screws into undershef leg collar. Position leg into leg collar to desired height and tighten set screw to secure legs

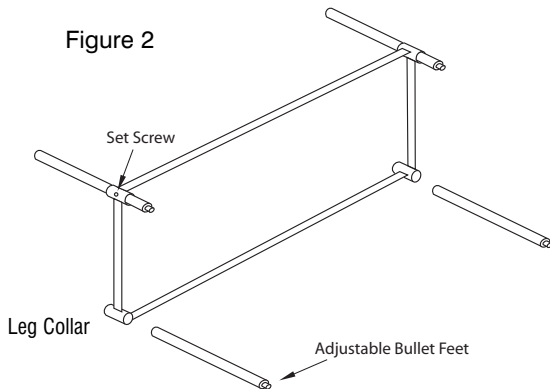

Figure 2

## Step 3:

Insert legs and undershef assembly into gussets of the table top as indicated in Figure 3. Tighten set screws.

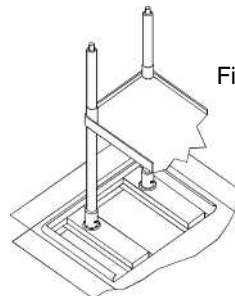
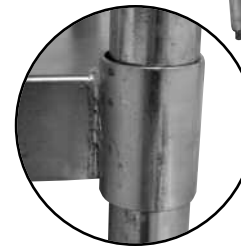

Figure 3

## FINAL STEP

Turn table upright and level by adjusting bullet feet.



Leg Collar

**NSF Installations require all set screws filled with an approved silicone sealer.**