

Quantity:

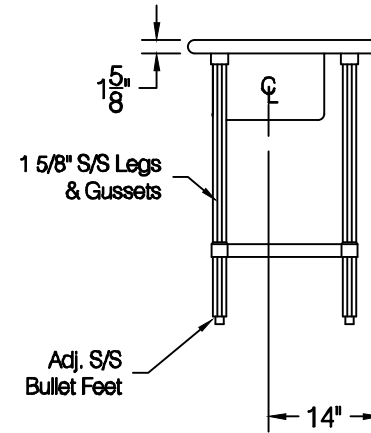

**ADVANCE TABCO**  
 325 Wireless Blvd.  
 Hauppauge, NY 11788  
 Tel: 800-645-3166  
 Fax: 631-242-4589  
 cad@advancetabco.com

Customer:	Order / Quote #	Sheet #		Original Drawing Date:		NO.	Revision Date:	By:	Print Approval:	
	4259					1				
	Job Name:	Model #	Item #	Material:		2				Accessory Locations MUST Be Verified Prior To Unit Being Fabricated
		FMS-246 / TA-11F		16 GA.304S/S		3				
	Purchase Order # :	Drawn By:	Scale:	Tolerance:		4				
	E.Mencarelli	1/2" = 12"	+ .500 - .500		5					
<b>FACTORY USE ONLY:</b>	WELDING:		Final Inspection:							
	1) Date: _____ Inspected By: _____ 2) Date: _____ Inspected By: _____		1) Date: _____ Inspected By: _____ 2) Date: _____ Inspected By: _____							

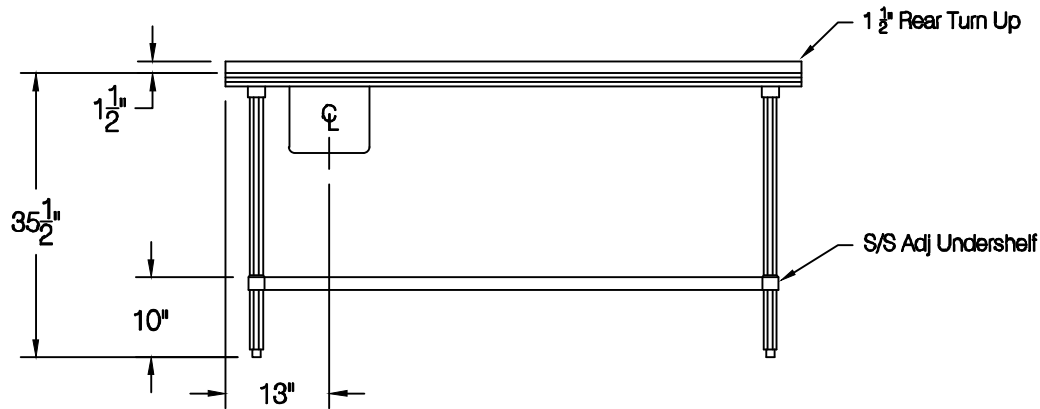
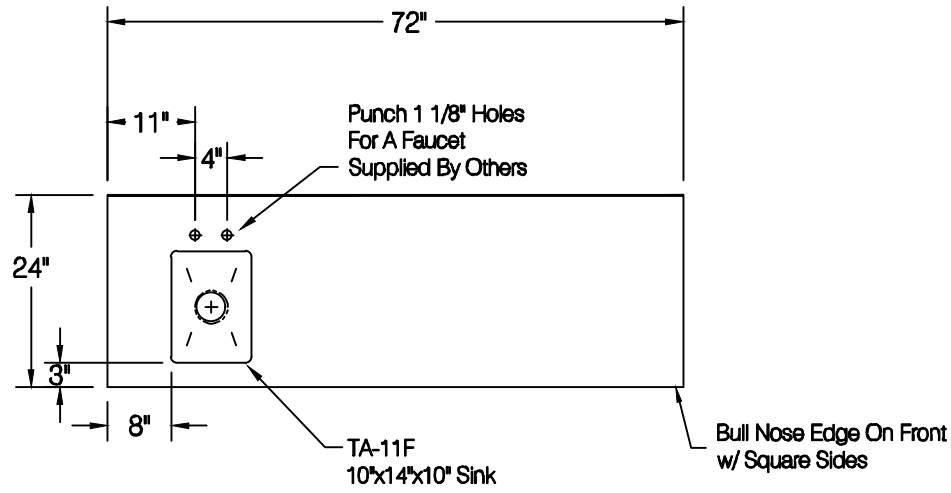