

Quantity:

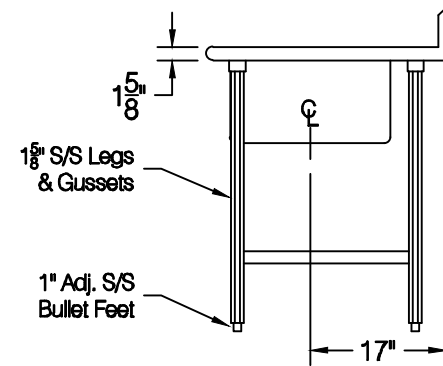
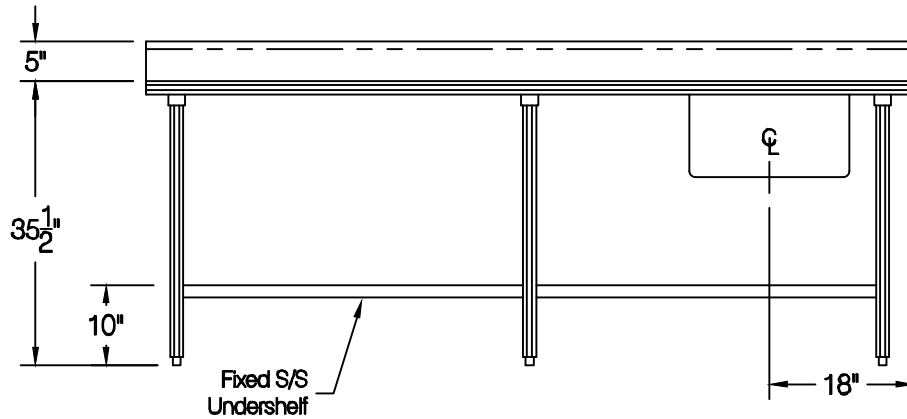
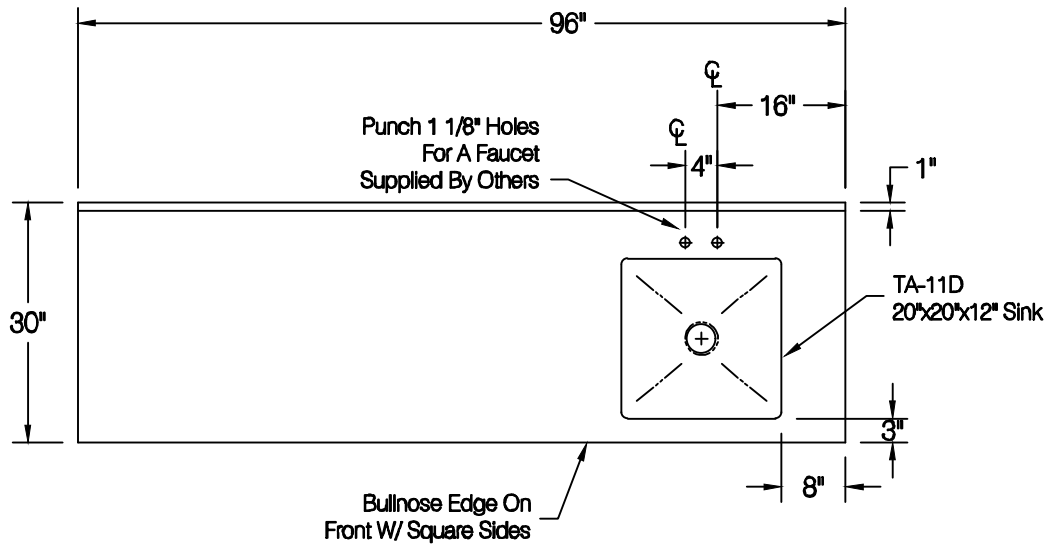

**ADVANCE TABCO**  
 325 Wireless Blvd.  
 Hauppauge, NY 11788  
 Tel: 800-645-3166  
 Fax: 631-242-4589  
 cad@advancetabco.com

Customer:	Order / Quote # <b>4253</b>	Sheet #	Original Drawing Date:	NO.	Revision Date:	By:	Print Approval:
Job Name:	Model # KMS-308 / TA-23	Item #	Material: 16 GA. 304 S/S	1			Accessory Locations MUST Be Verified Prior To Unit Being Fabricated
Purchase Order # :	Drawn By: E. Mencarelli	Scale: 1/2" = 12"	Tolerance: +.500 -.500	2			
<b>FACTORY USE ONLY:</b>	WELDING: 1) Date: _____ Inspected By: _____ 2) Date: _____ Inspected By: _____	Final Inspection: 1) Date: _____ Inspected By: _____ 2) Date: _____ Inspected By: _____	<b>NSF</b>	3			Approved By _____ Date _____
				4			Approved By _____ Date _____
				5			