

Quantity:

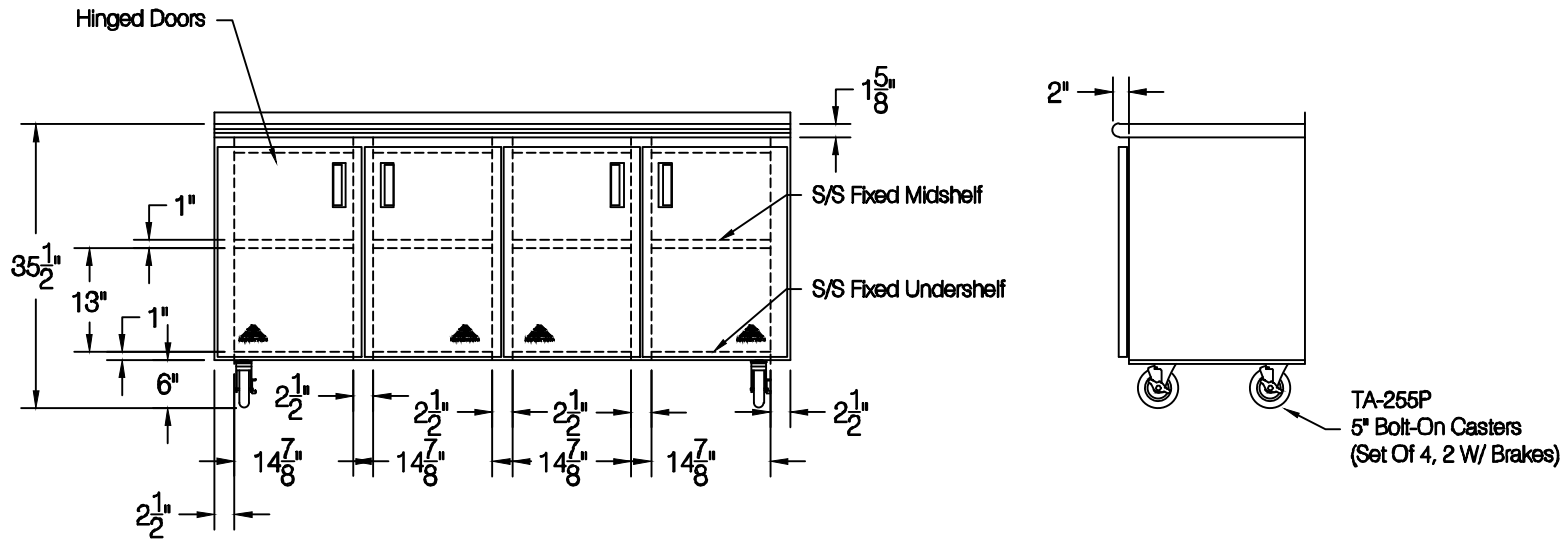

**ADVANCE TABCO**  
 325 Wireless Blvd.  
 Hauppauge, NY 11788  
 Tel: 800-645-3166  
 Fax: 631-242-4589  
 cad@advancetabco.com

Customer:	Order / Quote #	Sheet #	Original Drawing Date:	NO.	Revision Date:	By:	Print Approval:	
	<b>4238</b>			1				Accessory Locations MUST Be Verified Prior To Unit Being Fabricated
Job Name:	Model #	Item #	Material:	2				
	HF-SS-246M / TA-255P		14 GA.304S/S	3				
Purchase Order # :	Drawn By:	Scale:	Tolerance:	4			Approved By _____ Date _____	
	E. Mencarelli	1/2" = 12"	+ .500 - .500	5				
<b>FACTORY USE ONLY:</b>	WELDING:	Final Inspection:					Approved By _____ Date _____	
1) Date: _____ Inspected By: _____ 2) Date: _____ Inspected By: _____		1) Date: _____ Inspected By: _____ 2) Date: _____ Inspected By: _____						

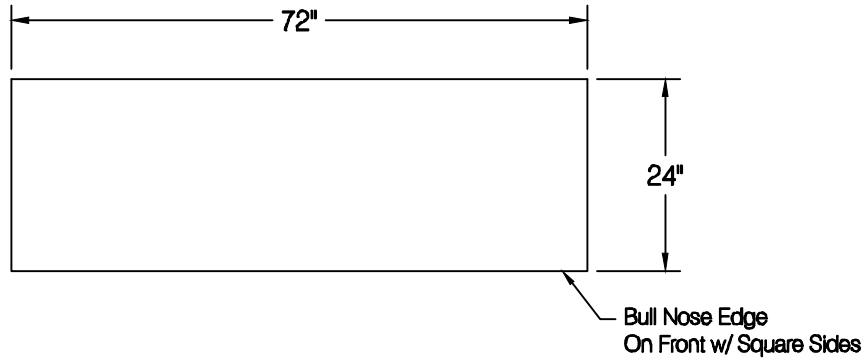