

Quantity:

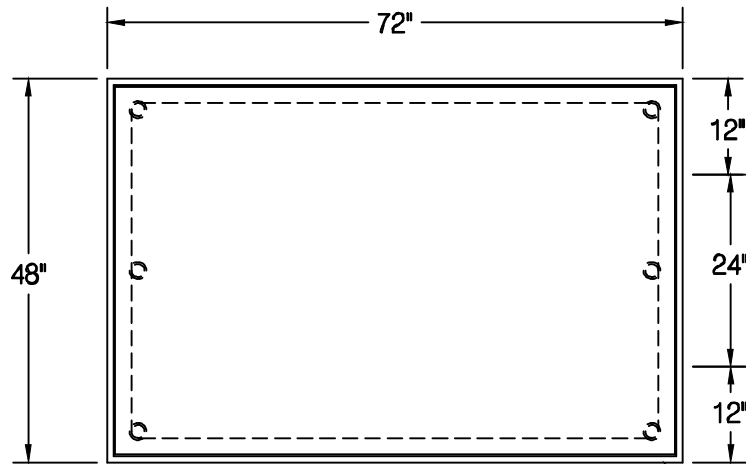

RIGHT END OF TABLE PREPARED FOR "CU" SHOWN BELOW, "CU" SHELF WILL NEED TO PURCHASED SEPARATELY

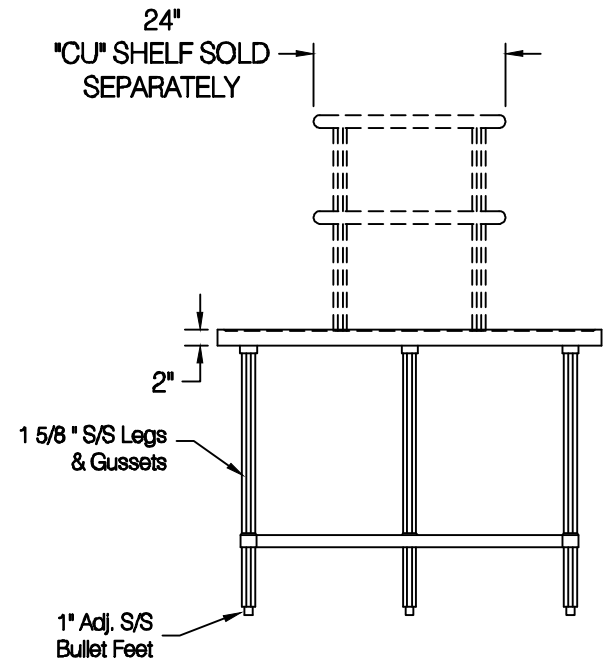
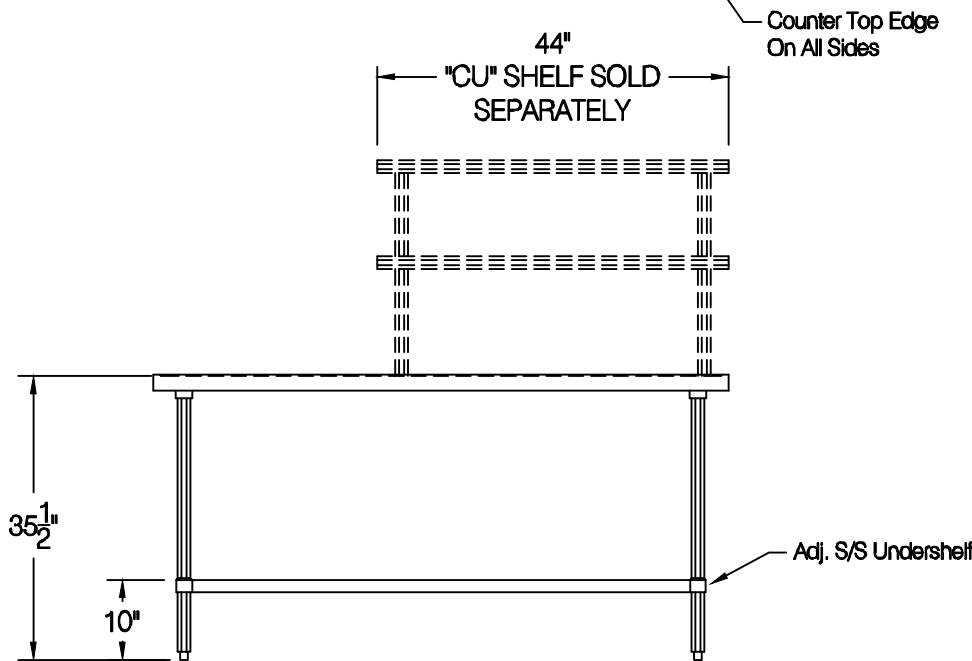

ADVANCE TABCO
 325 Wireless Blvd.
 Hauppauge, NY 11788
 Tel: 800-645-3166
 Fax: 631-242-4589
 cad@advancetabco.com

Customer:	Order / Quote # 4232	Sheet #	Original Drawing Date:	NO.	Revision Date:	By:	Print Approval:
Job Name:	Model # VSS-486	Item #	Material: 14 GA.304S/S	1			Accessory Locations MUST Be Verified Prior To Unit Being Fabricated
Purchase Order # :	Drawn By: E. Mencarelli	Scale: 1/2" = 12"	Tolerance: +.500 -.500	2			
FACTORY USE ONLY:	WELDING: 1) Date: _____ Inspected By: _____ 2) Date: _____ Inspected By: _____	Final Inspection: 1) Date: _____ Inspected By: _____ 2) Date: _____ Inspected By: _____	NSF	3			Approved By _____ Date _____
				4			Approved By _____ Date _____
				5			