

Quantity:

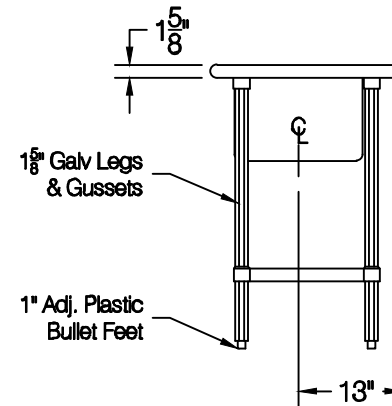

ADVANCE TABCO
 325 Wireless Blvd.
 Hauppauge, NY 11788
 Tel: 800-645-3166
 Fax: 631-242-4589
 cad@advancetabco.com

Customer:	Order / Quote #	4202	Sheet #	Original Drawing Date:	NO.	Revision Date:	By:	Print Approval:			
	Job Name:	Model #	Item #	Material:	1				Accessory Locations MUST Be Verified Prior To Unit Being Fabricated		
	Purchase Order # :	AG-244 / TA-11J		16GA. 430 S/S	2						
	FACTORY USE ONLY:	WELDING:	Drawn By:	Scale:	Tolerance:	3					Approved By _____ Date _____
		1) Date: _____ Inspected By: _____	E. Mencarelli	1/2" = 12"	+ .500 - .500	4					
	Final Inspection:				5			Approved By _____ Date _____			
	2) Date: _____ Inspected By: _____										

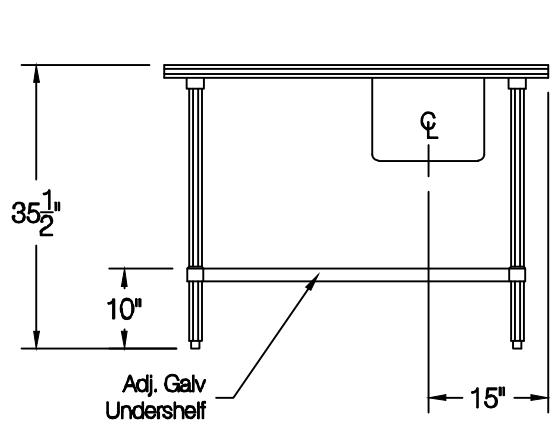
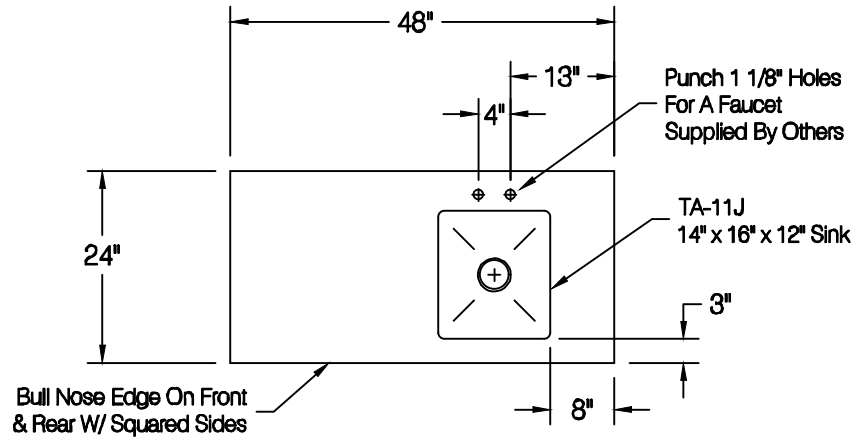