

Quantity:

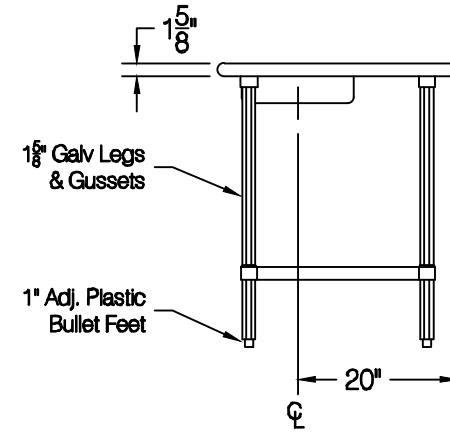

**ADVANCE TABCO**  
 325 Wireless Blvd.  
 Hauppauge, NY 11788  
 Tel: 800-645-3166  
 Fax: 631-242-4589  
 cad@advancetabco.com

|           |                                    |                                    |                                    |                                    |     |                |                              |                 |                                                                     |                              |
|-----------|------------------------------------|------------------------------------|------------------------------------|------------------------------------|-----|----------------|------------------------------|-----------------|---------------------------------------------------------------------|------------------------------|
| Customer: | Order / Quote #                    | 4197                               | Sheet #                            | Original Drawing Date:             | NO. | Revision Date: | By:                          | Print Approval: |                                                                     |                              |
|           | Job Name:                          | Model #                            | Item #                             | Material:                          | 1   |                |                              |                 | Accessory Locations MUST Be Verified Prior To Unit Being Fabricated |                              |
|           | Purchase Order # :                 | AG-304 / TA-11Q-2                  |                                    | 16 GA. 430S/S                      | 2   |                |                              |                 |                                                                     |                              |
|           | FACTORY USE ONLY:                  | Drawn By:                          | Scale:                             | Tolerance:                         | 3   |                |                              |                 |                                                                     | Approved By _____ Date _____ |
|           | WELDING:                           | E. Mencarelli                      | 1/2" = 12"                         | + .500<br>- .500                   | 4   |                |                              |                 |                                                                     |                              |
|           | Final Inspection:                  |                                    |                                    | 5                                  |     |                | Approved By _____ Date _____ |                 |                                                                     |                              |
|           | 1) Date: _____ Inspected By: _____ | 2) Date: _____ Inspected By: _____ | 1) Date: _____ Inspected By: _____ | 2) Date: _____ Inspected By: _____ |     |                |                              |                 |                                                                     |                              |

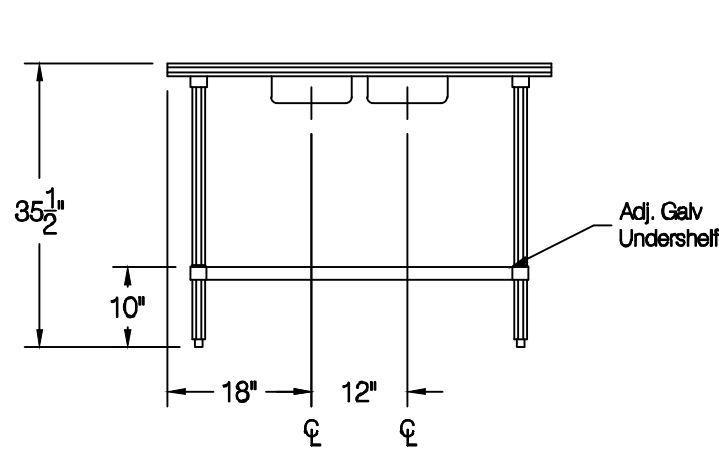
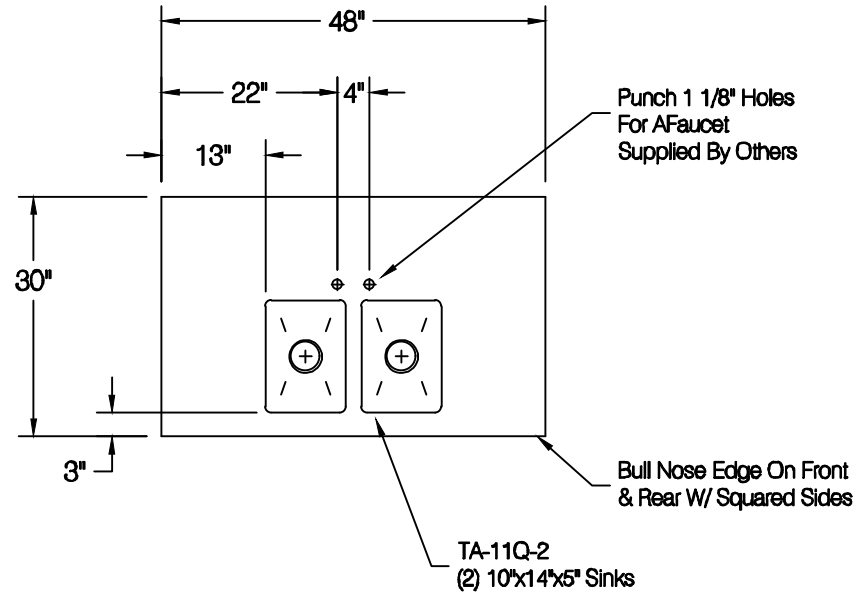