

Quantity:

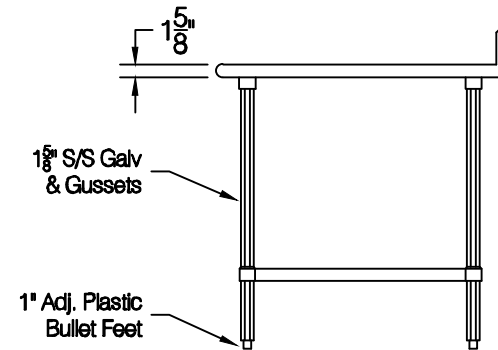

**ADVANCE TABCO**  
325 Wireless Blvd.  
Hauppauge, NY 11788  
Tel: 800-645-3166  
Fax: 631-242-4589  
cad@advancetabco.com

<b>FACTORY USE ONLY:</b> WELDING: 1) Date: _____ Inspected By: _____ 2) Date: _____ Inspected By: _____ Final Inspection: 1) Date: _____ Inspected By: _____ 2) Date: _____ Inspected By: _____	Customer:	Order / Quote # <b>4177</b>	Sheet #	Original Drawing Date: 10/5/2023	NO.	Revision Date:	By:	Print Approval:
	Job Name:	Model # KAG-363 / TA-61	Item #	Material: 16 GA. 430 S/S	1			Accessory Locations MUST Be Verified Prior To Unit Being Fabricated
	Purchase Order # :	Drawn By: E. Mencarelli	Scale: 1/2" = 12"	Tolerance: +.500 -.500	2			
					3			Approved By _____ Date _____
					4			
				5				
								Approved By _____ Date _____

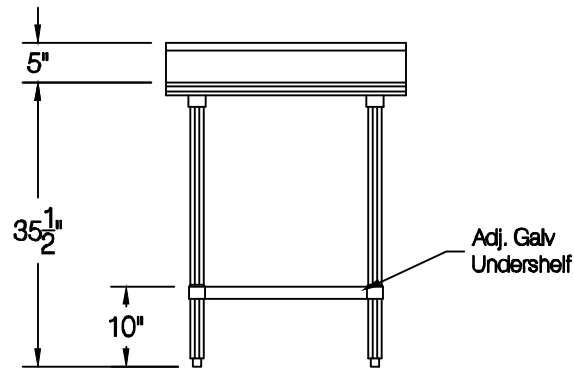
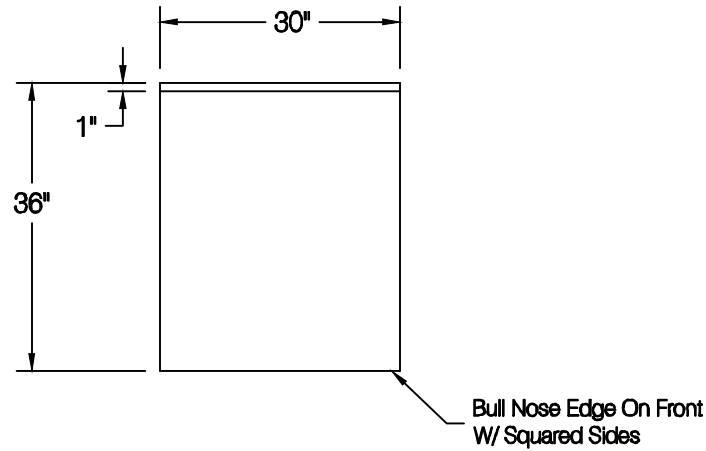