

Quantity:

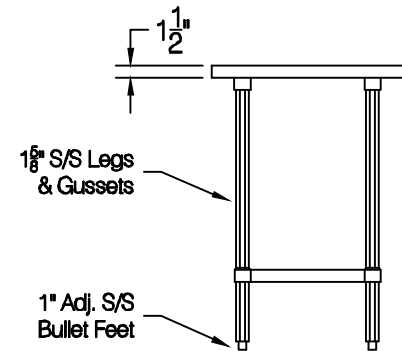

ADVANCE TABCO
 325 Wireless Blvd.
 Hauppauge, NY 11788
 Tel: 800-645-3166
 Fax: 631-242-4589
 cad@advancetabco.com

Customer:	Order / Quote #	Sheet #		Original Drawing Date:	NO.	Revision Date:	By:	Print Approval:	
	4173			10/5/2023	1				
	Job Name:	Model #	Item #	Material:	2				Accessory Locations MUST Be Verified Prior To Unit Being Fabricated
		MS-248 / TA-22		16GA. 304 S/S	3				
	Purchase Order # :	Drawn By:	Scale:	Tolerance:	4				Approved By _____ Date _____
	E. Mencarelli	1/2" = 12"	+ .500 - .500	5					
FACTORY USE ONLY:	WELDING:	Final Inspection:						Approved By _____ Date _____	
	1) Date: _____ Inspected By: _____ 2) Date: _____ Inspected By: _____	1) Date: _____ Inspected By: _____ 2) Date: _____ Inspected By: _____							

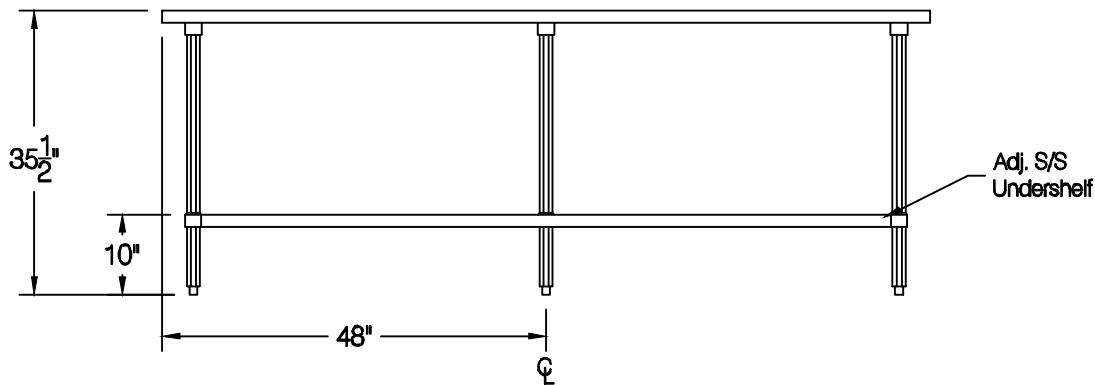
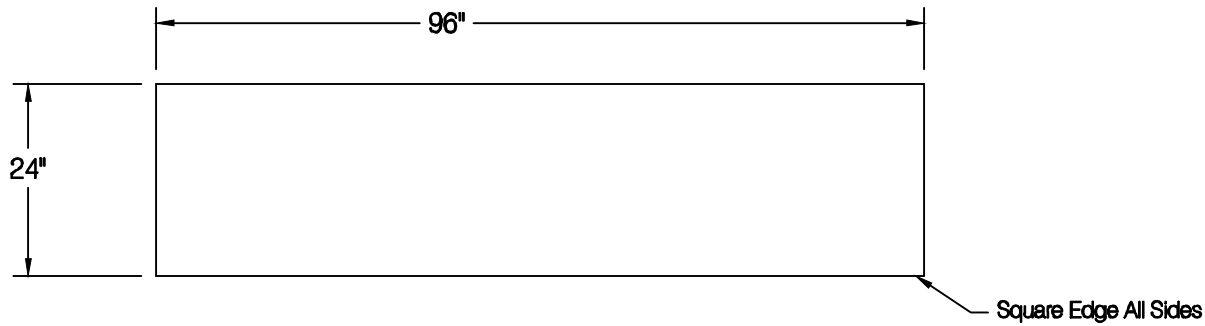