

Quantity:

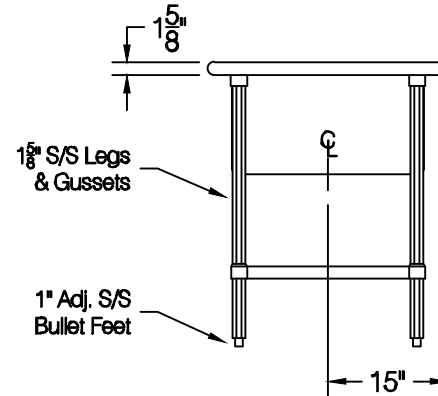
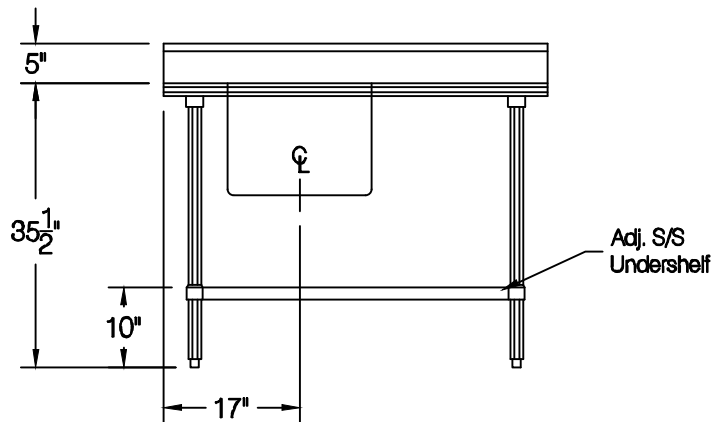
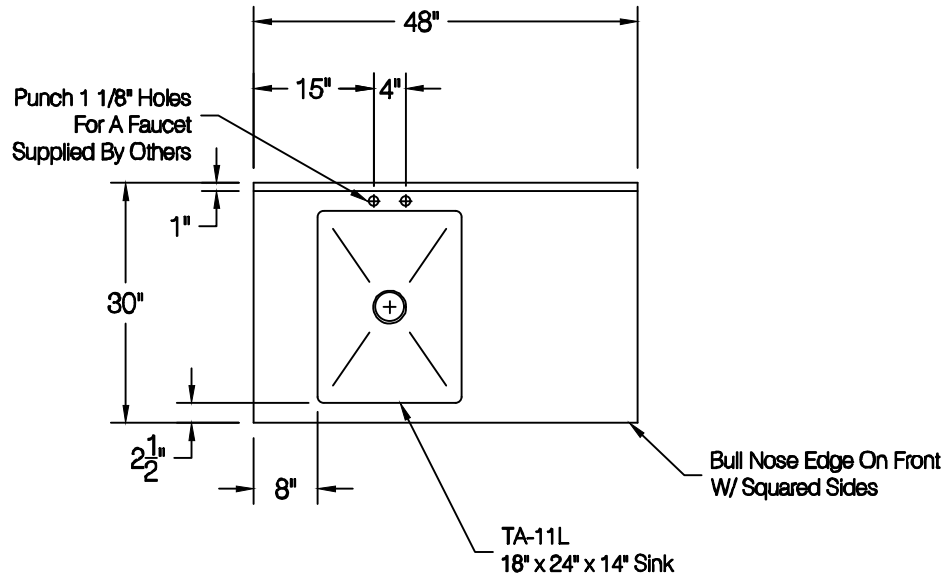

**ADVANCE TABCO**  
 325 Wireless Blvd.  
 Hauppauge, NY 11788  
 Tel: 800-645-3166  
 Fax: 631-242-4589  
 cad@advancetabco.com

Customer:	Order / Quote #	Sheet #		Original Drawing Date:	NO.	Revision Date:	By:	Print Approval:	
	4158			10/4/2023	1				
	Job Name:	Model #	Item #	Material:	2				Accessory Locations MUST Be Verified Prior To Unit Being Fabricated
		SKG-304 / TA-11L		16 GA. 430S/S	3				
	Purchase Order # :	Drawn By:	Scale:	Tolerance:	4				
	E. Mencarelli	1/2" = 12"	+ .500 - .500	5			NSF	Approved By _____ Date _____	
FACTORY USE ONLY:	WELDING:	Final Inspection:							
	1) Date: _____ Inspected By: _____ 2) Date: _____ Inspected By: _____	1) Date: _____ Inspected By: _____ 2) Date: _____ Inspected By: _____							