

Quantity:

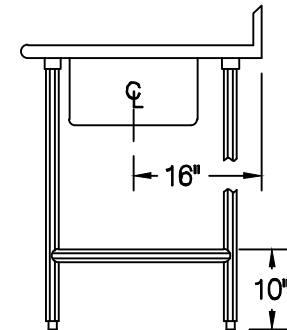

**ADVANCE TABCO**  
325 Wireless Blvd.  
Hauppauge, NY 11788  
Tel: 800-645-3166  
Fax: 631-242-4589  
cad@advancetabco.com

Customer:	Order / Quote #	Sheet #	Original Drawing Date:	NO.	Revision Date:	By:	Print Approval:	
	4156		10/4/2023	1				
	Job Name:	Model #	Item #	Material:	2			Accessory Locations MUST Be Verified Prior To Unit Being Fabricated
		TSKG-304 / TA-11J		16 GA. 430 S/S	3			
	Purchase Order # :	Drawn By:	Scale:	Tolerance:	4			
	E. Mencarelli	1/2" = 12"	+ .500 - .500	5				
FACTORY USE ONLY:	WELDING:	Final Inspection:		Approved By _____ Date _____				
	1) Date: _____ Inspected By: _____ 2) Date: _____ Inspected By: _____	1) Date: _____ Inspected By: _____ 2) Date: _____ Inspected By: _____						

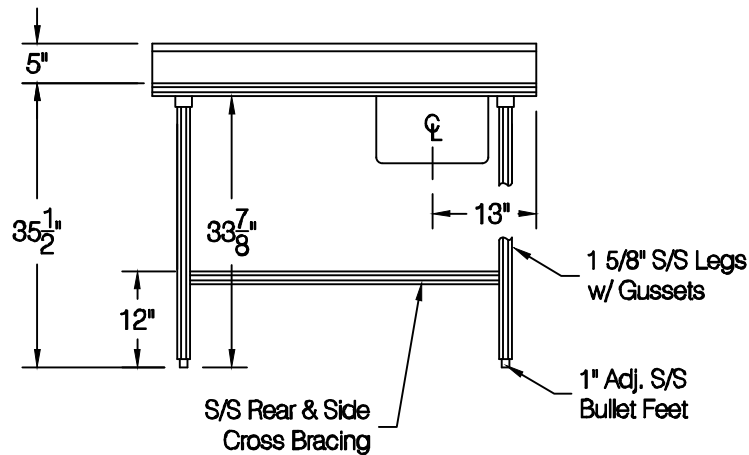
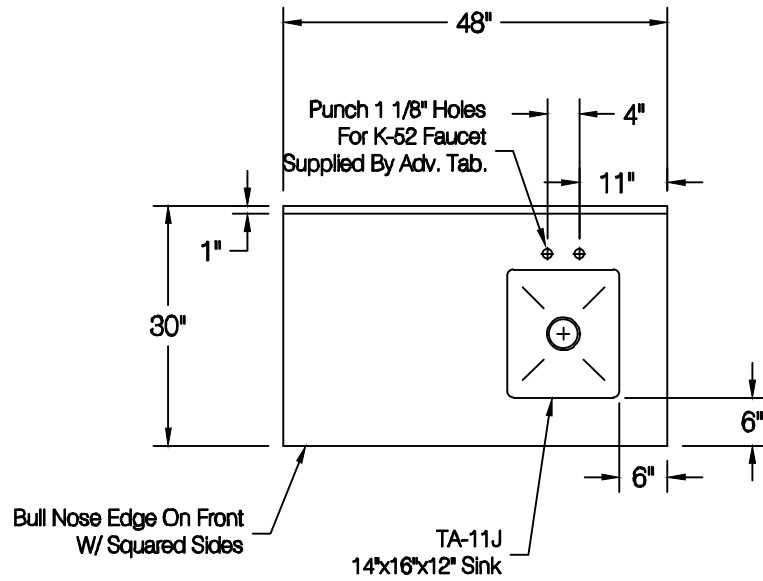