

Quantity:

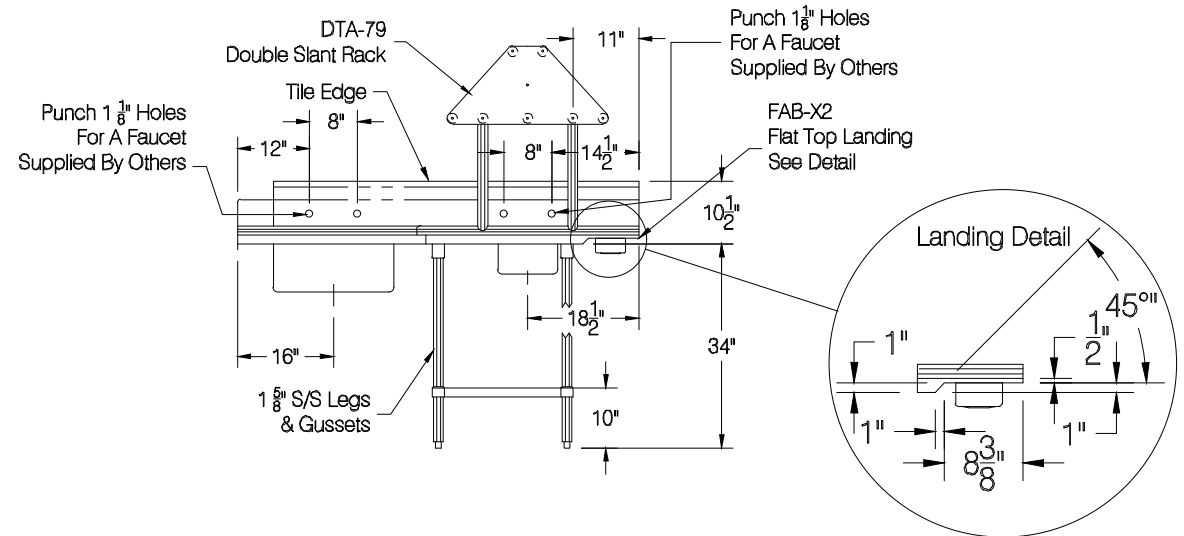
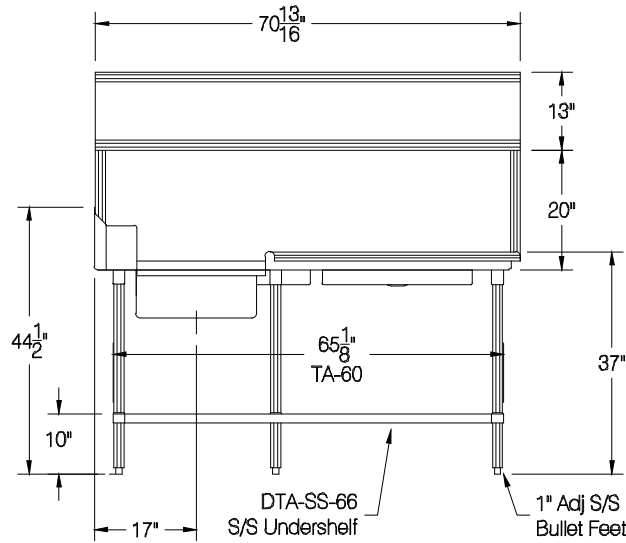
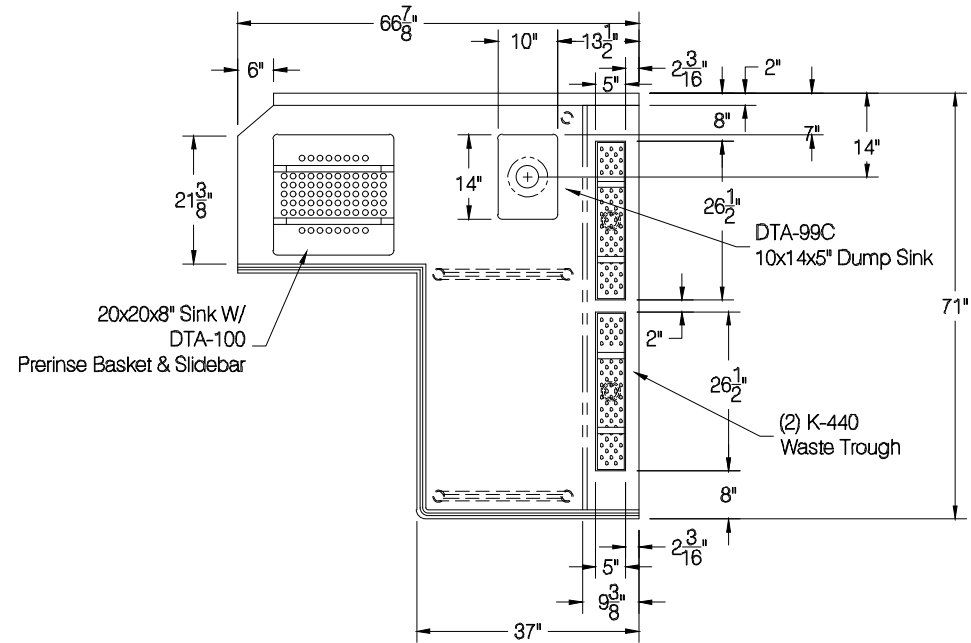

ADVANCE TABCO
325 Wireless Blvd.
Hauppauge, NY 11788
Tel: 800-645-3166
Fax: 631-242-4589
cad@advancetabco.com

Customer:	Order / Quote # 4134	Sheet #	Original Drawing Date: 9/12/2023	NO.	Revision Date:	By:	Print Approval:	
Job Name:	Model # DTS-D30-72R	Item #	Material: 14 GA. 304 S/S	1			Accessory Locations MUST Be Verified Prior To Unit Being Fabricated	
Purchase Order # :	Drawn By: E. Mencarelli	Scale: 3/8" = 12"	Tolerance: + .500 - .500	2				
FACTORY USE ONLY:	WELDING: 1) Date: _____ Inspected By: _____ 2) Date: _____ Inspected By: _____	Final Inspection: 1) Date: _____ Inspected By: _____ 2) Date: _____ Inspected By: _____	NSF	3				Approved By _____ Date _____
				4				
				5				
							Approved By _____ Date _____	