

Quantity:

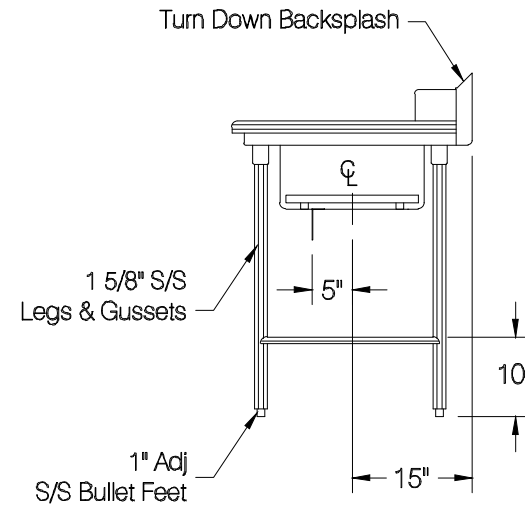
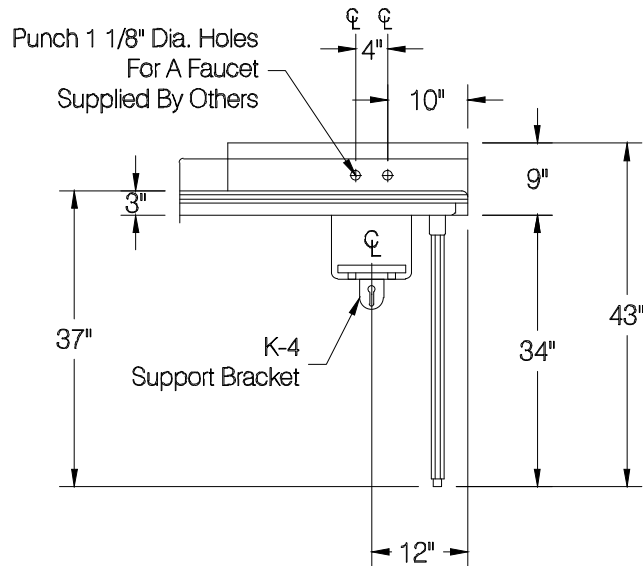
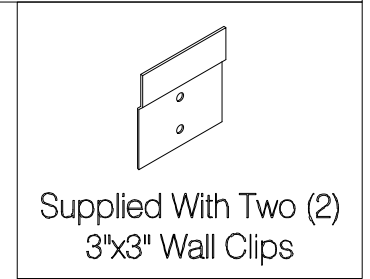
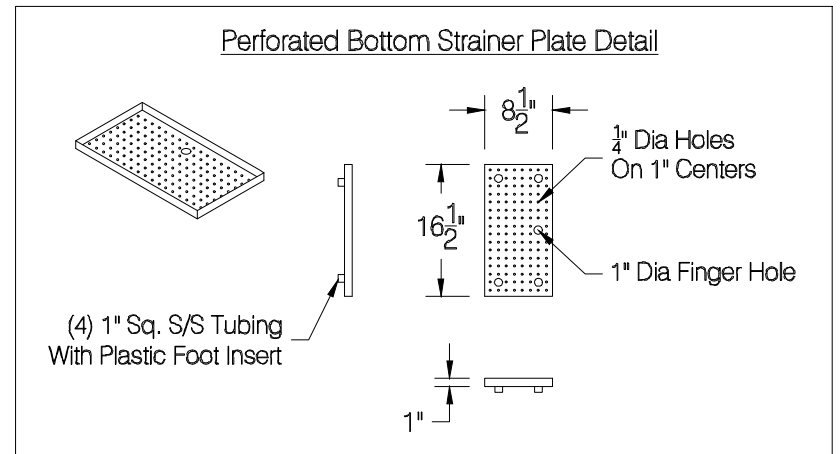
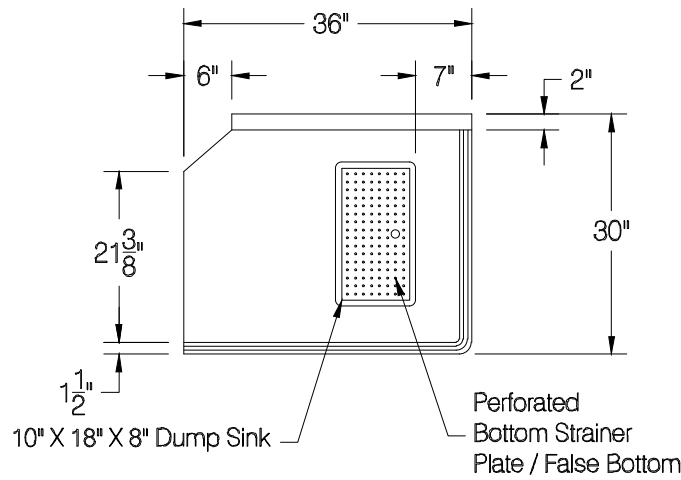

ADVANCE TABCO
 325 Wireless Blvd.
 Hauppauge, NY 11788
 Tel: 800-645-3166
 Fax: 631-242-4589
 cad@advancetabco.com

Customer:	Order / Quote # 4114	Sheet #	Original Drawing Date: 9/12/2023	NO.	Revision Date:	By:	Print Approval:
Job Name:	Model # DTS-S70-36R-BW	Item #	Material: 16 GA. 304 S/S	1			Accessory Locations MUST Be Verified Prior To Unit Being Fabricated
Purchase Order # :	Drawn By: E. Mencarelli	Scale: 1/2" = 12"	Tolerance: + .500 - .500	2			
FACTORY USE ONLY:	WELDING: 1) Date: _____ Inspected By: _____ 2) Date: _____ Inspected By: _____	Final Inspection: 1) Date: _____ Inspected By: _____ 2) Date: _____ Inspected By: _____	NSF	3			Approved By _____ Date _____
				4			Approved By _____ Date _____
				5			Approved By _____ Date _____