

Quantity: 1

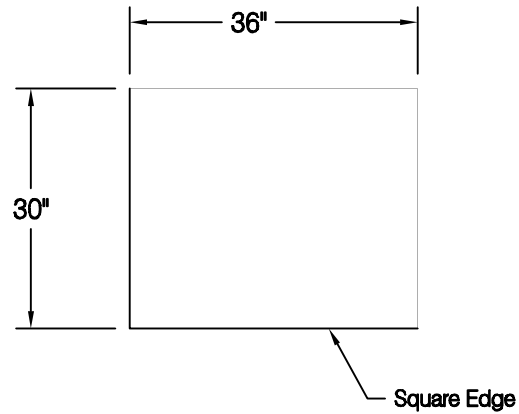

UNIT IS WELDED SET UP

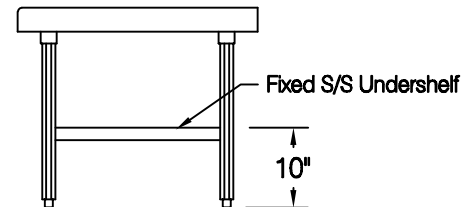
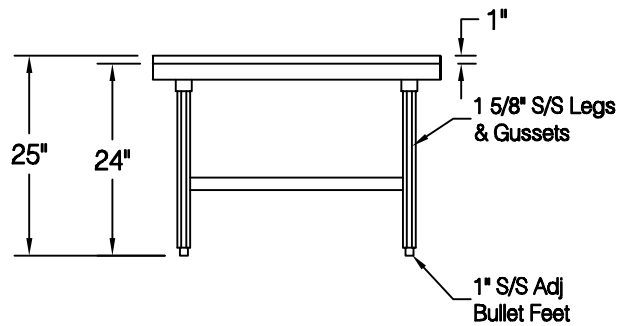

**ADVANCE TABCO**  
 325 Wireless Blvd.  
 Hauppauge, NY 11788  
 Tel: 800-645-3166  
 Fax: 631-242-4589  
 cad@advancetabco.com

Customer:	Order / Quote# <b>4001</b>	Sheet #	Original Drawing Date:	NO.	Revision Date:	By:	Print Approval:	
Job Name:	Model # ES-303 / TA-23	Item #	Material: 14 GA. 304 S/S	1			Accessory Locations MUST Be Verified Prior To Unit Being Fabricated	
Purchase Order # :	Drawn By: E. Mencarelli	Scale: 1/2" = 12"	Tolerance: +.500 -.500	2				Approved By _____ Date _____
FACTORY USE ONLY:	WELDING: 1) Date: _____ Inspected By: _____ 2) Date: _____ Inspected By: _____	Final Inspection: 1) Date: _____ Inspected By: _____ 2) Date: _____ Inspected By: _____	NSF	3			Approved By _____ Date _____	
				4				
				5				