

Quantity: 1

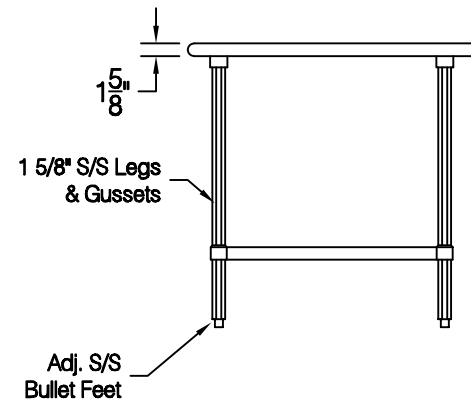

ADVANCE TABCO
325 Wireless Blvd.
Hauppauge, NY 11788
Tel: 800-645-3166
Fax: 631-242-4589
cad@advancetabco.com

Customer:	Order / Quote # 196	Sheet #	Original Drawing Date:	NO.	Revision Date:	By:	Print Approval:
Job Name:	Model # SFG-364 / TA-61	Item #	Material: 16 GA. 430 S/S	1			Accessory Locations MUST Be Verified Prior To Unit Being Fabricated
Purchase Order # :	Drawn By: E. Mencarelli	Scale: 1/2" = 12"	Tolerance: +.500 -.500	2			
FACTORY USE ONLY:	WELDING: 1) Date: _____ Inspected By: _____ 2) Date: _____ Inspected By: _____	Final Inspection: 1) Date: _____ Inspected By: _____ 2) Date: _____ Inspected By: _____		3			Approved By _____ Date _____
				4			Approved By _____ Date _____
				5			

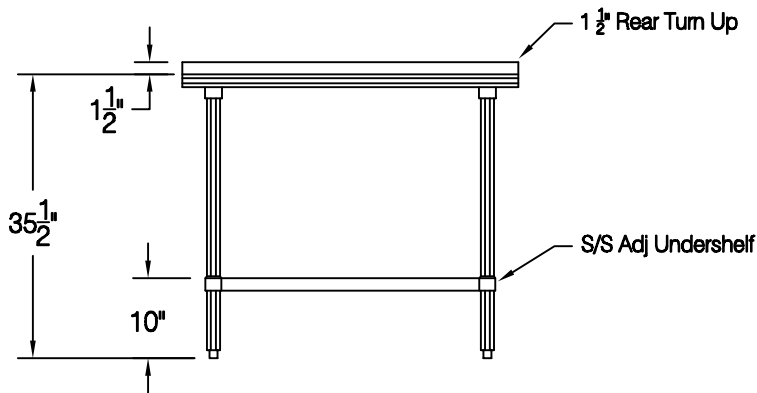
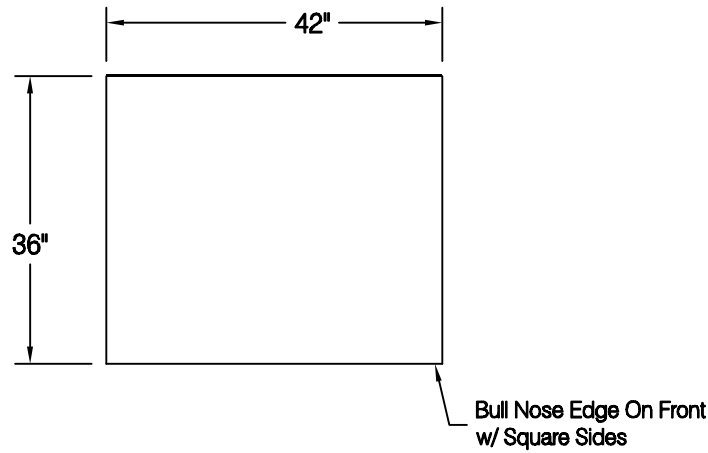