

Quantity: 1

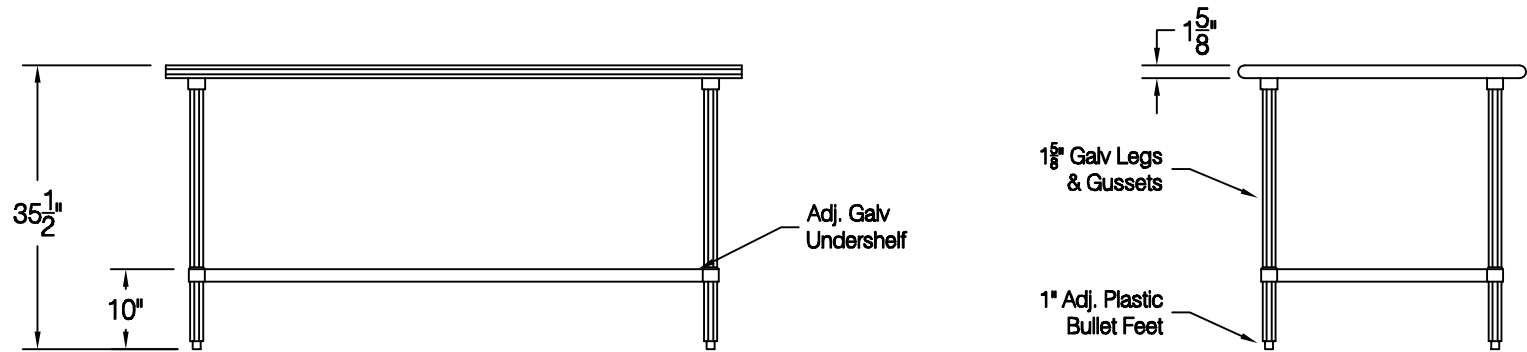
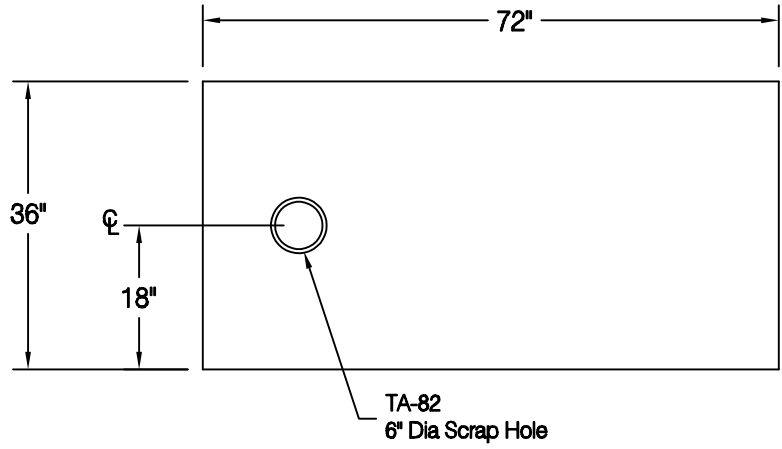

ADVANCE TABCO
 325 Wireless Blvd.
 Hauppauge, NY 11788
 Tel: 800-645-3166
 Fax: 631-242-4589
 cad@advancetabco.com

Customer:	Order / Quote#	Sheet #	Original Drawing Date:	NO.	Revision Date:	By:	Print Approval:
	151		7/1/2020	1			
Job Name:	Model #	Item #	Material:	2			Accessory Locations MUST Be Verified Prior To Unit Being Fabricated
	AG-366	1	16 GA. 430 S/S	3			
Purchase Order # :	Drawn By:	Scale:	Tolerance:	4			Approved By _____ Date _____
	E. Mencarelli	1/2" = 12"	+ .500 - .500	5			
FACTORY USE ONLY:	WELDING:	Final Inspection:					Approved By _____ Date _____
	1) Date: _____ Inspected By: _____ 2) Date: _____ Inspected By: _____	1) Date: _____ Inspected By: _____ 2) Date: _____ Inspected By: _____					